



PRODUCT SHEET  
**AMMA 6060**  
 60" X 60" X 21"



<b>THERMOMASSEUR® BATH</b>	\$
<b>TUB</b>	\$

THERMOMASSEUR (TMU)	
Jets	55
2 heated backrests (Independently controlled)	included
2 heated headrests (Independently controlled)	included
MiaPlus® Control	included
Geysair®	included
AromaCloud®	\$
Illuzio Chromatherapy <b>NEW</b>	\$

TUB (soaker)	
AromaCloud®	\$
Illuzio Chromatherapy <b>NEW</b>	\$
WarmTouchShell®	\$
DOT control	included with therapy
2 <sup>nd</sup> WarmTouchShell®	\$

FEATURES			
Installation types	Drop-in & Corner		
No. of bathers		Inverted V	2
US gallons	64	Armrests	2
Imp. gallons	54	Grab bar (color match)	1
Raised seats	2		

OPTIONAL UPCHARGE APPLICABLE		
<b>COLOR</b>		
<b>Standard</b>		
White	Biscuit	
<b>Optional</b>		
		\$
Gray		
<b>CONTROL (TMU ONLY)</b>		
MiaMulti®		\$
<b>SKIRT</b> <b>SJ-3 CR AMMA 6060</b>		
Skirt		\$
Optional color		\$
<b>CLEAR ACRYLIC GRAB BARS</b>		
With Chrome, Brass or Brushed nickel inserts		\$
<b>DRAIN &amp; OVERFLOW</b> <b>16" X 35"</b> <b>INTEGRATED WASTE &amp; OVERFLOW</b>		
Chrome	\$	\$
White, Biscuit	\$	\$
Brass	\$	\$
Brushed nickel, Polished nickel	\$	\$
Oil-rubbed bronze	\$	N/A
<b>TILE FLANGE</b>		
Ordered with bath, uninstalled		\$
Factory-installed		\$

1 800 463.2187 From 8 a.m. to 8 p.m. Monday to Thursday (EST)  
 info@bainultra.com From 8 a.m. to 5 p.m. on Friday (EST)

# AMMA 6060 60" X 60" X 21"

## ACCESSORIES (OPTIONAL)

CUTTING TEMPLATE

# 90000040

OTHER

Optional tile flange.

TOTAL PRICE

\$

## DROP-IN/CORNER INSTALLATION

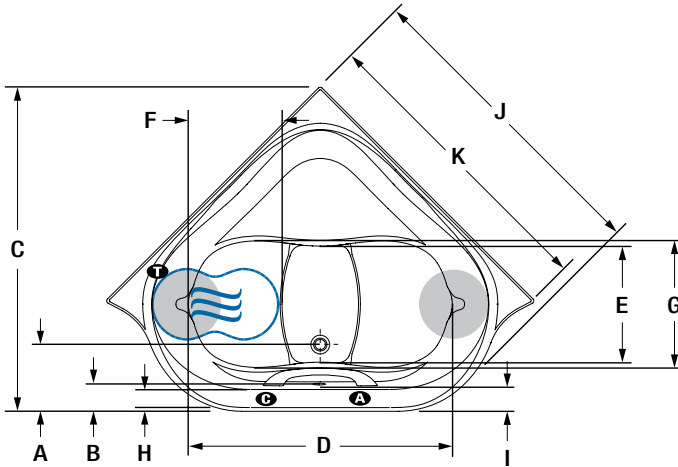

LETTER	DESCRIPTION	MEASURE
A	Outside edge to center drain	12 7/8"
B	Outside edge to overflow	5"
C	Total length	61 3/4"
D	Bathing well length	50 3/4"
E	Bathing well width at foot area	22"
F	Raised seat length	18"
G	Raised seat width	24"
H	Flat surface width	3 1/4"
I	Deck width	4 5/8"
J	Length from sidewall to front curve	59 1/2"
K	Sidewall length	58"
L	Total height to headrest	23 1/2"
M	Height from bottom of tub to top deck	21 1/4"
N	Height from bottom of tub to bottom of lip	19 1/4"
O	Height from drain to center of overflow	17"
P	Maximum water level	15 3/8"
Q	Slope of backrest	18°

- A** AromaCloud position
- G** Control position when factory-installed (Mia or Dot)
- T** Turbine position (TMU)
- Heated backrest (TMU)
- ☄ WarmTouchShell position

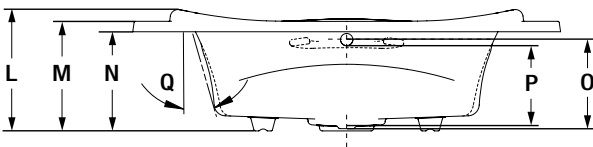

## TECHNICAL SPECIFICATIONS

### Hot water supply required

Should be 70% of water capacity of tub or greater.

### Turbine

Access to the pump must be at least 18" X 22". **Standard connection is 20 A, 120 V, 60 hz**, dedicated line with a Ground-Fault Circuit Interrupter (GFCI). **For any additional option, a second line is needed 15 A, 120 V, 60 hz**, dedicated line with a GFCI. Air vent necessary: 2" X 4" minimum

Our products must be installed by certified professionals only and according to our Owner's Manual as well as federal, provincial/state and local building codes and regulations ([www.bainultra.com/documentation/documentation](http://www.bainultra.com/documentation/documentation)).

### Approx. shipping weight

210 lbs

### Turbine power

550 W

### Air heater

600 W

## WARRANTY

Controls-LED-Geysair\*

5 years

Bath & turbine\*

20 years

\*Some restrictions apply | [www.bainultra.com/warranty](http://www.bainultra.com/warranty)



The specifications shown indicate the outer edge dimension and the inside bathing capacity dimension measured at air jets' height. The manufacturer accepts a 1/4" [0.64 cm] variance. There are variations on each product and specifications are subject to change as we improve upon our product as required. The dimensions needed for site preparation and structure building will differ. BainUltra® assumes no responsibility for preparatory work done prior to the product being on site.