

PRODUCT SHEET  
**OPALIA 6839**  
 CENTERED ELLIPSE 68" X 39" X 25"



<b>THERMOMASSEUR® BATH</b>	\$
<b>TUB</b>	\$

THERMOMASSEUR (TMU)	
Jets	35
1 heated backrest	included
MiaPlus® Control (uninstalled)	included
Geysair®	included
AromaCloud®	\$
Illuzio Chromatherapy <b>NEW</b>	\$
2 <sup>nd</sup> heated backrest	\$

TUB (soaker)	
AromaCloud®	\$
Illuzio Chromatherapy <b>NEW</b>	\$
WarmTouchShell®	\$
DOT control	included with therapy
2 <sup>nd</sup> WarmTouchShell®	\$

FEATURES			
Installation type	Freestanding		
No. of bather		Imp. gallons	42
US gallons	51	Integrated waste & overflow	inst. & incl.
INTEGRATED WASTE & OVERFLOW			
Chrome, White			
Brass, Brushed Nickel, Polished Nickel			

FEATURES	
COLOR	
Standard	
<input type="checkbox"/>	White

OPTIONAL UPCHARGE APPLICABLE	
FINISH	
UltraVelour Matte Finish (White Only)	\$
CONTROL (TMU ONLY)	
MiaMulti® (uninstalled)	\$
ISLAND TUB DRAIN™*	
Island Tub Drain™	\$

DON'T FORGET THAT THIS MODEL IS AVAILABLE IN WHITE ONLY.  
 DON'T FORGET TO SPECIFY THE FINISH OF THE INTEGRATED WASTE & OVERFLOW.  
 \* AN ISLAND TUB DRAIN IS REQUIRED WHEN THERE IS NO ACCESS UNDER THE BATH.

1 800 463.2187 info@bainultra.com | From 8 a.m. to 8 p.m. Monday to Thursday (EST)  
 From 8 a.m. to 5 p.m. on Friday (EST)

# OPALIA 6839 CENTERED ELLIPSE 68" X 39" X 25"

## ACCESSORIES (OPTIONAL)

CUTTING TEMPLATE

#90000073

### OTHERS

- Faucet must be freestanding or wall-mounted.
- The turbine must be remotely installed.

TOTAL PRICE

\$

## FREESTANDING INSTALLATION

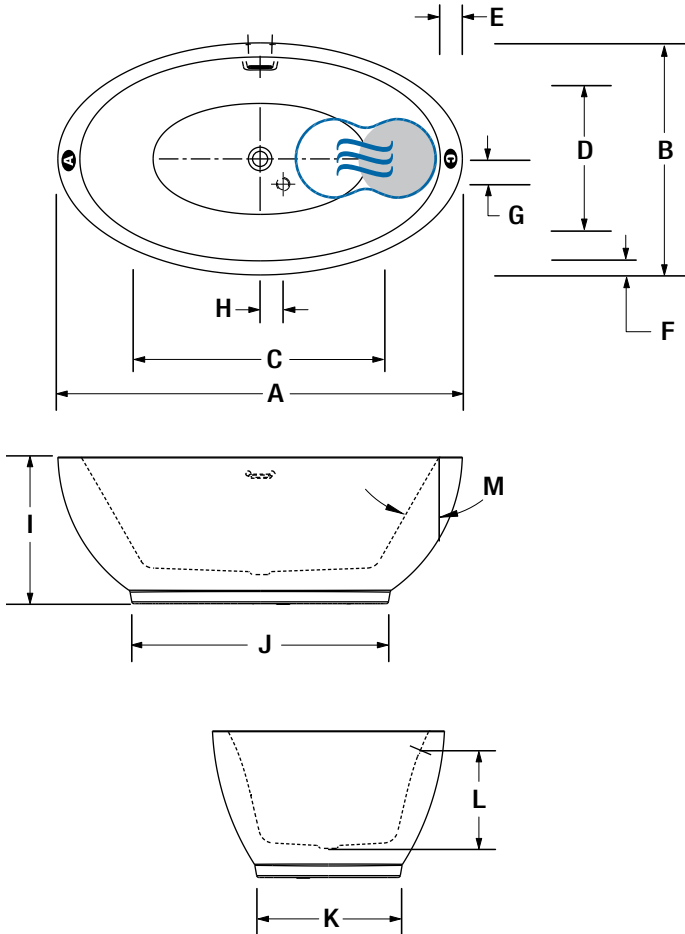

LETTER	DESCRIPTION	MEASURE
A	Total length	68"
B	Total width	39"
C	Bathing well length (at height of jets)	41 5/8"
D	Bathing well width (at height of jets)	23 5/8"
E	Deck width (backrest)	3 3/4"
F	Deck width (sides)	2 3/8"
G	Distance from air intake to center of waste (long axis)	4 1/4"
H	Distance from air intake to center of waste (trans. axis)	3 7/8"
I	Tub height	24 3/4"
J	Length of the base	43"
K	Width of the base	24"
L	Height from waste to center of overflow	16"
M	Slope of backrest	31°

**A** AromaCloud position

**C** Control position when factory-installed (Mia or Dot)

● Heated backrest (TMU)

☞ WarmTouchShell position

## TECHNICAL SPECIFICATIONS

### Hot water supply required

Should be 70% of water capacity of tub or greater.

### Turbine

Access to the pump must be at least 18" X 22". **Standard connection is 20 A, 120 V, 60 hz, dedicated line with a Ground-Fault Circuit Interrupter (GFCI). For any additional option, a second line is needed 15 A, 120 V, 60 hz, dedicated line with a GFCI.**

Our products must be installed by certified professionals only and according to our Owner's Manual as well as federal, provincial/state and local building codes and regulations ([www.bainultra.com/documentation/documentation](http://www.bainultra.com/documentation/documentation)).

**Approx. shipping weight**

230 lbs

**Turbine power**

550 W

**Air heater**

600 W

## WARRANTY

Controls-LED-Geysair\*

5 years

Bath & turbine\*

20 years

\*Some restrictions apply | [www.bainultra.com/warranty](http://www.bainultra.com/warranty)

The specifications shown indicate the outer edge dimension and the inside bathing capacity dimension measured at air jets' height. The manufacturer accepts a 1/4" [0,64 cm] variance. There are variations on each product and specifications are subject to change as we improve upon our product as required. The dimensions needed for site preparation and structure building will differ. BainUltra® assumes no responsibility for preparatory work done prior to the product being on site.

