



PRODUCT SHEET
SENSATION
 54" X 54" X 20"



THERMOMASSEUR® BATH	\$
TUB	\$

THERMOMASSEUR (TMU)	
Jets	40
1 heated backrest	included
1 heated headrest	included
Mia® Control	included
Geysair®	included
AromaCloud®	\$
Illuzio Chromatherapy NEW	\$
2 nd heated backrest (advanced technology)	\$

TUB (soaker)	
AromaCloud®	\$
Illuzio Chromatherapy NEW	\$
WarmTouchShell®	\$
DOT control	included with therapy
2 nd WarmTouchShell®	\$

FEATURES			
Installation types	Drop-in or Corner		
No. of bathers		Imp. gallons	46
US gallons	55	Grab bar (color match)	1

OPTIONAL UPCHARGE APPLICABLE

COLOR

Standard	
White	Biscuit
Optional	
	\$
Gray	

CONTROL (TMU ONLY)

MiaPlus®*	\$
MiaMulti®	\$

SKIRT **SJ-3 SE**

Skirt	\$
Optional color	\$

CLEAR ACRYLIC GRAB BARS

With Chrome, Brass or Brushed nickel inserts	\$
--	----

WASTE & OVERFLOW **16" X 35"**

Chrome	\$
White & Biscuit	\$
Brass	\$
Brushed nickel, Polished nickel & Oil-rubbed bronze	\$

TILE FLANGE

Ordered with bath, uninstalled	\$
Factory-installed	\$

SPECIFY COLOR FOR THE CONTROL, WHITE OR BISCUIT.
 *THE MIAPLUS CONTROL IS INCLUDED WHEN PURCHASING CHROMATHERAPY ON A TMU.

1 800 463.2187 **From 8 a.m. to 8 p.m. Monday to Thursday (EST)**
info@bainultra.com **From 8 a.m. to 5 p.m. on Friday (EST)**

SENSATION 54" X 54" X 20"

ACCESSORIES (OPTIONAL)

CUTTING TEMPLATE

90000014

OTHER

Optional tile flange.

TOTAL PRICE

\$

DROP-IN/CORNER INSTALLATION

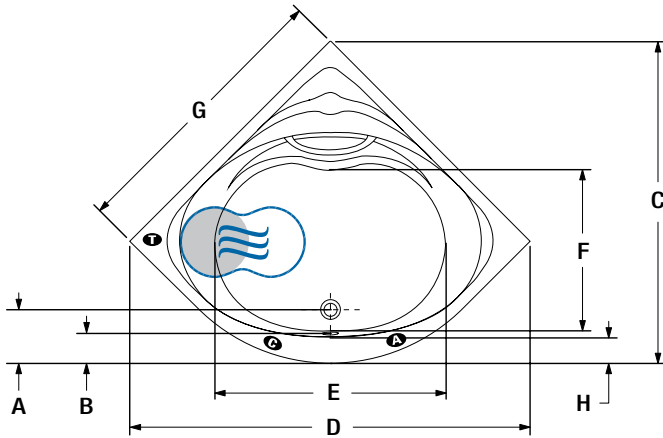

LETTER	DESCRIPTION	MEASURE
A	Outside edge to center drain	10 1/2"
B	Outside edge to overflow	5 1/2"
C	Total length	58 7/8"
D	Total width	75 7/8"
E	Bathing well length	44"
F	Bathing well width	28 7/8"
G	Sidewall length	53 7/8"
H	Deck width (widest point)	5 1/4"
I	Total height to raised headrest	22 1/4"
J	Height from bottom of tub to top deck	20 1/4"
K	Height from bottom of tub to bottom of lip	18 3/4"
L	Height from drain to center of overflow	15 3/4"
M	Maximum water level	14"
N	Slope of backrest	21°

A AromaCloud position

● Heated backrest (TMU)

C Control position when factory-installed (Mia or Dot)

☞ WarmTouchShell position

I Turbine position (TMU)

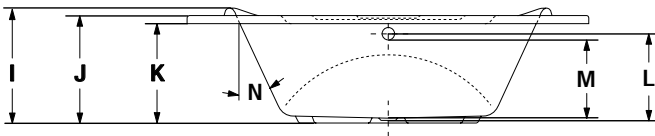

TECHNICAL SPECIFICATIONS

Hot water supply required

Should be 70% of water capacity of tub or greater.

Turbine

Access to the pump must be at least 18" X 22". **Standard connection is 20 A, 120 V, 60 hz**, dedicated line with a Ground-Fault Circuit Interrupter (GFCI). **For any additional option, a second line is needed 15 A, 120 V, 60 hz**, dedicated line with a GFCI. Air vent necessary: 2" X 4" minimum

Our products must be installed by certified professionals only and according to our Owner's Manual as well as federal, provincial/state and local building codes and regulations (www.bainultra.com/documentation/documentation).

Approx. shipping weight

135 lbs

Turbine power

550 W

Air heater

600 W

WARRANTY

Controls-LED-Geysair*

5 years

Bath & turbine*

20 years

*Some restrictions apply | www.bainultra.com/warranty



The specifications shown indicate the outer edge dimension and the inside bathing capacity dimension measured at air jets' height. The manufacturer accepts a 1/4" [0,64 cm] variance. There are variations on each product and specifications are subject to change as we improve upon our product as required. The dimensions needed for site preparation and structure building will differ. BainUltra® assumes no responsibility for preparatory work done prior to the product being on site.